

# Commissioning Chilled Water TES Systems

As we've seen in recent articles, good commissioning experience can make valuable design advice. This recent ASHRAE presenter provides an overview of TES options before getting into details: tank placement relative to coil placement, tips on using (and not using) pumps and valves, thermocline issues, and multiple tank considerations.

BY LUCAS B. HYMAN, P.E.

**A** goal of the commissioning process is to deliver a project that, at the end of construction, is fully functional and meets the owner's needs. Some of the fundamental objectives of the commissioning process are to:

- Clearly document the owner's project requirements (OPR);
- Provide documentation tools (basis of design, commissioning plan, design, and construction checklists);
- Help with coordination between parties (owner, engineer, and contractor);
- Accomplish ongoing verification that the engineering and construction achieve the OPR;
- Verify that complete O&M manuals are provided to the owner;
- Verify that maintenance personnel are properly trained; and
- Accomplish functional performance tests that document proper operation prior to owner acceptance.

This article highlights the following:

- Key OPR for a stratified CHW TES system;
- Successful CHW TES design strategies (basis of design);
- Caution flags (lessons learned);
- Guidelines of ASHRAE Standard 150,

"Method of Testing the Performance of Cool Storage Systems requirements;" and

- Key CHW TES information to obtain during testing.

## TES BASICS

TES is a method by which energy (cooling or heating) is produced and stored at one time period for use during a different time period. For cooling applications, using thermal storage can result in the reduction of electricity costs, chiller equipment size, and maintenance costs.

There are two basic concepts in TES and each has different major advantages. The two concepts are partial storage and full storage.

Partial-storage systems use smaller chillers, cooling towers, and a TES system to provide a facility's daily total cooling load needs, with a plant running at a constant load about equal in tons to 1/24 of the daily total ton-hours. The partial-storage system has an advantage by allowing for a smaller, less costly chiller plant than a conventional chiller plant.

Full-storage systems typically require larger storage systems and larger chiller plants than partial storage systems. Full-storage systems hold the chiller plant off during the period of highest energy charges (the on-peak period) and meet the cooling load solely from thermal storage during that period.

Typically, the thermal storage capacity is gen-

# Commissioning Chilled Water

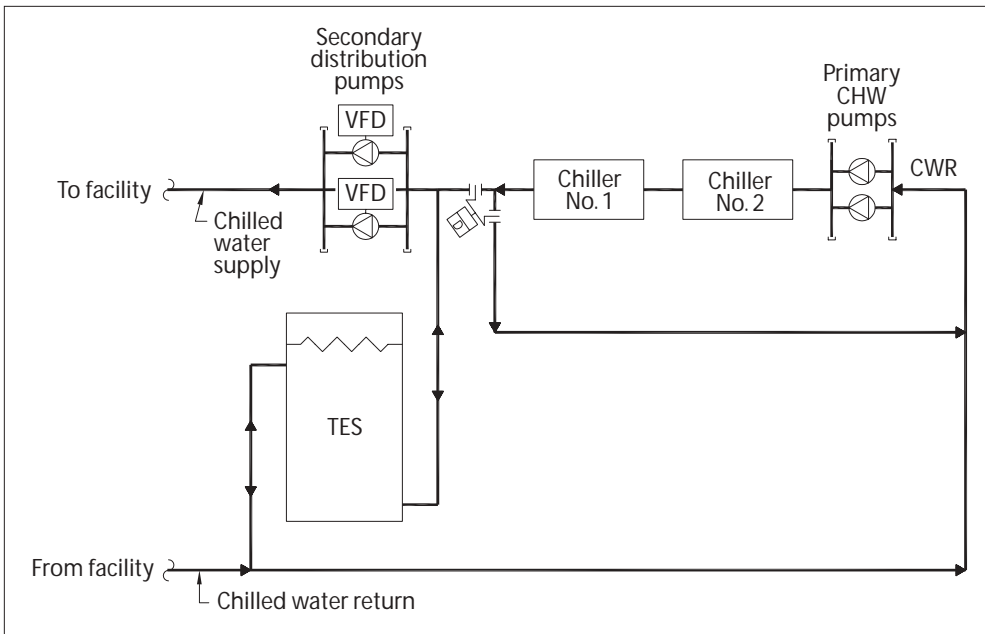

FIGURE 1. A schematic for a simple CHW TES system.

erated at night or in an off-peak period, when electric rates are lower and building cooling requirements are low. Full-storage system chillers, towers, and buildings are often about the same size as conventional chiller plants but this depends on the storage strategy, cooling load profile, and electrical rate structure.

Full-storage TES systems, therefore, gain their major advantage from the difference between on-peak and off-peak electric demand charges and energy rates. Partial storage systems also benefit from these factors to a smaller degree. Since TES allows the shift of electrical demand and energy consumption to off-peak periods, users can achieve large electricity cost savings when the central plant uses electric-drive chillers.

## OWNER TES PROJECT REQUIREMENTS

An owner, of course, wants a facility that is flexible, expandable, and also one that represents a reasonable capital investment. TES systems are often installed because they represent the lowest life-cycle-cost option. In addition, key OPR of a CHW TES system typically include:

- Required thermal storage capacity (often measured in ton-hours);
- Design CHW  $\Delta T$ ;
- Peak cooling day profile; and
- The thermal storage strategy to be employed.

The design CHW  $\Delta T$  (temperature difference between the CHW supply and return temperatures) is a critical piece of information since with a stratified TES system, the thermal storage capacity is directly proportional to the  $\Delta T$  ( $Q = Mc\Delta T$ ). Also, as CHW systems operate with relatively small  $\Delta T$ s, even a few degrees less than the design  $\Delta T$  can have a dramatic impact. For example, on a  $16^\circ\Delta T$  system, a  $1^\circ$  drop in  $\Delta T$  to  $15^\circ$  represents a 6% loss of TES capacity.

The  $\Delta T$  of the distribution system and/or the chiller system is not necessarily the same as that in the TES tank. The chillers must, however, produce water at least as cold as that stored in the TES tank. The CHW return temperature from the building(s) coils determines how high the CHW return temperature will be.

The peak day cooling load profile not only shows the facility's peak

cooling load, and the shape and nature of the load, but also provides the day's required ton-hours as represented by the area under the cooling load profile curve. Along with the CHW  $\Delta T$ , the peak day's cooling load in ton-hours and the TES strategy to be employed were key information used by the designer to size the TES tank.

## SUCCESSFUL CHW TES DESIGN STRATEGIES (BASIS OF DESIGN)

In order to help ensure that the OPR are met at the end of the project, our experience indicates that successful CHW TES strategies employ:

- High  $\Delta T$  CHW systems;
- Variable flow with two-way valves — constant  $\Delta T$  systems;
- Simple controls;
- TES tank at high point (desirable but not necessary); and
- A single constant dynamic point.

As noted above, it is extremely important to maintain a constant and a high  $\Delta T$  for a successfully stratified CHW TES. This cannot be overstated; it is key to the economic success of TES. A CHW system operated or designed for  $10^\circ$  vs.  $20^\circ\Delta T$  requires twice the TES tank capacity and flow rate to achieve the same cooling load. In addition, the TES tank costs are substantially higher. Also, pumping energy is roughly proportional to the cube of the flow. Thus, all else being equal, twice the flow rate requires nearly eight times the pumping horsepower and energy. Of course, to help achieve high  $\Delta T$ s, it is critical to use variable flow with two-way valves to control cooling loads.

TES systems can be designed with simple controls or complex controls. It is no surprise that TES systems with simple controls are easier to commission. Figure 1 shows a schematic for a simple CHW TES system. With this simple system, if the facility cooling load is less than chiller output, CHW is stored in the TES tank. Conversely, when facility cooling load is greater than chiller output, CHW is discharged from the TES tank. No TES controls are required, no operator decisions are required, and no complicated algorithms comparing temperatures and flows are required.

As a typical CHW TES tank is an "open" tank (i.e., vented to the atmosphere), it is preferred if the TES tank can be located so that the TES tank water level is higher than any other point in the CHW system. Otherwise pressure-sustaining valves or other pressure control/separation methods are required.

## CAUTION FLAGS (LESSONS LEARNED)

Team members should exercise care when dealing with TES systems that have:

- Building coils higher than the TES tank;
- Multiple TES tanks operating simultaneously;
- Lack of or poor  $\Delta T$  control;
- High campus CHW system differential pressure; and
- Systems with multiple pumps/valve trees with complex controls.

High CHW system differential pressures can contribute to low  $\Delta T$  syndrome, as two-way control valves near the central plant can be forced open, thereby resulting in bypass flow. That is, the control valves cannot

# Commissioning Chilled Water

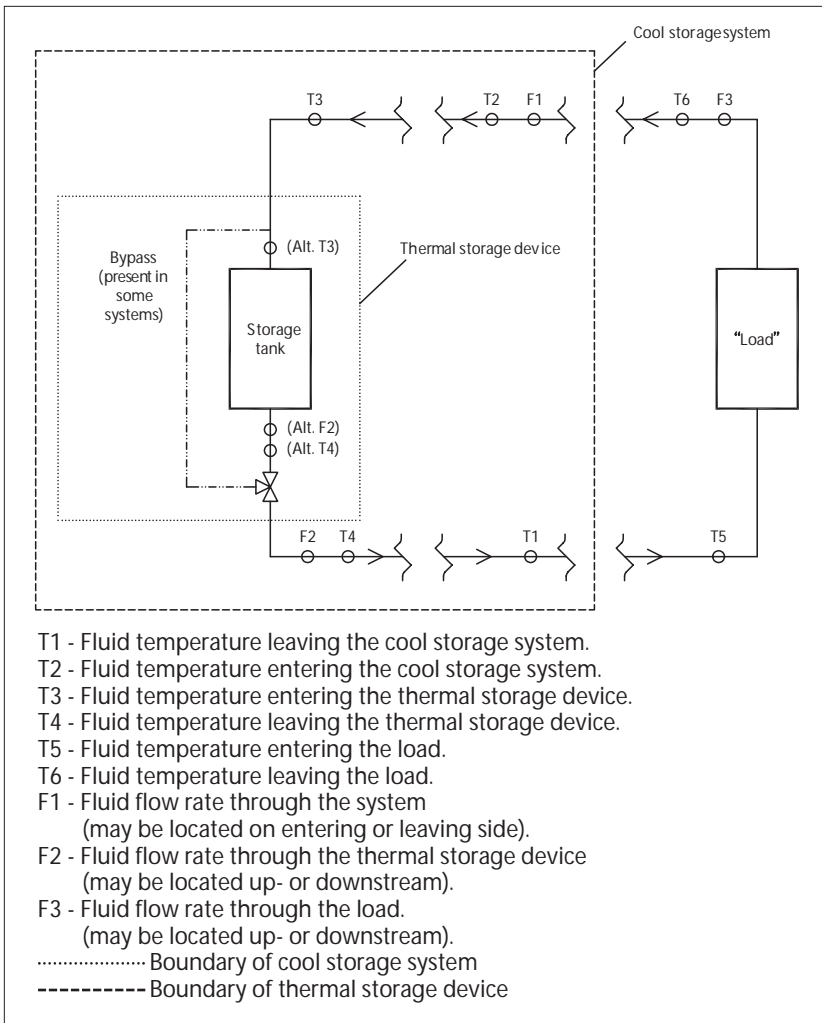

FIGURE 2. A general cool storage system test schematic showing typical instrumentation requirements and locations. (Reprinted with permission from ASHRAE.)

withstand the high  $\Delta P$ s causing excessive flows and low  $\Delta T$  due to the chilled water supply flowing to the chilled water return without any controlled heat gain.

While beyond the scope of this article, multiple CHW TES tank design should proceed with care. When adding a second tank, flow cannot be simply doubled in the first TES tank to charge/discharge the first TES tank in half the time. As both tanks are open, water levels must be identical. If attempting to charge or discharge both TES tanks simultaneously, hydraulic profiles for each system will need to be identical. Extra care must be paid to points of connection and hydraulic profiles (which are dynamic) to prevent surging.

While a complex control system can be made to work, why not keep it simple if possible? We've helped start up some systems that have multiple dedicated TES pumps, multiple valves for various charging and discharging modes, and multiple temperature sensors for flow control. At one particular site, we were able to show that the TES system worked perfectly without the dedicated TES pumps and valves (a case for getting the commissioning authority involved at the start of design vs. the end of construction).

## ASHRAE STANDARD 150

The purpose of ASHRAE Standard 150, "Method of Testing the Performance of Cool Storage Systems," is to "prescribe a uniform set of test-

ing procedures for determining the cooling capacities and efficiencies of cool storage systems." The Standard 150 test is the functional performance test at the end of the project that evaluates if the project as a whole achieved the OPR. Standard 150 in brief covers the requirements for:

- Testing;
- Instrumentation;
- Test methods and procedures;
- Data and calculations; and
- The test report.

Important aspects of ASHRAE Standard 150 are that it requires and details initialization requirements (e.g., the TES system shall be operated through at least five cycles before testing), the testing apparatus required (e.g., flow and temperature elements), and points to be measured. Standard 150 also provides instrumentation calibration procedures, and accuracy, precision, and resolution requirements to minimize test uncertainty. For example, temperature difference sensors must have accuracy of at least plus or minus  $0.2^\circ$ , and flow meters must be installed with 20 pipe diameters upstream and 10 diameters downstream in order to achieve an uncertainty of plus or minus 10%.

To meet ASHRAE Standard 150 requirements, the following are completed:

- Discharge test;
- Charge test;
- Cool storage capacity test; and
- The cool storage system efficiency test.

The charge and discharge tests may be performed simultaneously. One issue that often arises is that rarely will the facility be experiencing the peak cooling load at the time that functional performance tests are conducted. For example, the TES system may be constructed during the winter period so as to be ready for the summer cooling season. ASHRAE Standard 150 provides some methods of accounting for this common occurrence including operating existing or temporary heat in conditioned spaces to provide a "false" cooling load.

Some of the key CHW TES data to be documented through these tests are:

- CHW TES tank storage capacity;
- Thermocline thickness;
- Diffuser pressure drop;
- Tank heat gain; and
- Load profile achievement.

The thermocline is the region where the CHW changes temperature between the CHW supply and the CHW return and represents lost capacity in the TES tank. Temperature sensors located vertically every 2 ft or so measure and provide the TES tank's temperature profile. The diffusers are a critical component of a CHW TES tank and, if properly designed, allow the CHW to be supplied or withdrawn in a laminar (i.e., nonturbulent) manner to prevent mixing in the TES tank between the CHW supply and CHW return. With respect to CHW pump sizing, the design engineer planned for a maximum pressure drop through the diffusers, which should be verified.

Figure 2 shows typical instrumentation requirements and locations. Temperature sensors are required at the inlet and outlet of the TES tank, as well as at the inlet and outlet of the chiller plant. As noted, chiller plant

# Commissioning Chilled Water

and TES tank inlet and outlet temperatures may be different due to chiller operation and blending/bypassing. Likewise, temperature measurements of CHW supply and return temperatures may also be desirable at the load itself.

Also as noted, for a stratified CHW TES system, temperature elements will also be needed vertically from the bottom to the top of the tank to determine the percentage of tank charge and the thickness of the thermocline. Flow rate into/from the TES tank can either be measured upstream or downstream of the tank.

Note that with a CHW TES system, chilled water flows reverse depending on whether the tank is being charged or discharged. During the charging mode, cold CHW supply is pumped into the bottom of the TES tank and warm CHW return is drawn from the top of the tank. Conversely, during the discharge mode, cold CHW supply is drawn from the bottom of the TES tank and warm CHW return is pumped to the top of the tank.

## SUMMARY

Ideally, the commissioning process starts during the programming phase of a project, with the commissioning authority involved throughout planning, design, construction, and operation (first year). Key to the success of the project is documenting and continually evaluating the OPR. Key basis-of-design items for stratified CHW TES system are the peak day cooling load profile and the “shape” of the load curve (which establishes the required ton-hours); the TES strategy (full or partial storage); and the chilled water system  $\Delta T$ . The  $\Delta T$  is a critical factor with stratified TES systems in obtaining the design thermal storage capacity and predicted economic results.

Whenever possible, design and construct simple systems that do not require complicated controls or sequences of operations to operate properly. Installing a single TES tank so that the water level is above the highest coil will simplify the system. **ES**

---

*Hyman is a LEED-accredited, professional mechanical engineer with more than 25 years of experience and is currently the president of Goss Engineering, Inc. His professional career has included projects for major universities, government agencies, schools, hospitals, industrial facilities, the military, and private firms. He has won numerous regional and chapter ASHRAE awards and is the author of several published papers and articles. He has planned and designed central heating and cooling plants, TES systems, cogeneration plants, steam plant systems, utility distribution systems, laboratory systems, HVAC improvements, energy conservation measures, landfill gas collection systems, fuel storage and distribution systems, as well as other mechanical systems. He can be reached at [LBH@GossEngineering.com](mailto:LBH@GossEngineering.com).*

